

Incremental encoders

Insulated blind hollow shaft $\varnothing 12...16$ mm, cone shaft $\varnothing 17$ mm

500...5000 pulses per revolution

HOG 86



HOG 86.2 T

Technical data - electrical ratings

Voltage supply	9...30 VDC 5 VDC $\pm 5\%$
Consumption w/o load	≤ 100 mA
Pulses per revolution	500...5000
Phase shift	$90^\circ \pm 20^\circ$
Scan ratio	45...55 % (40...60 % >3072 pulses per revolution)
Reference signal	Zero pulse, width 90°
Sensing method	Optical
Output frequency	≤ 120 kHz ≤ 300 kHz (on request)
Output signals	K1, K2, K0 + inverted Error output (only EMS)
Output stages	HTL-P (power linedriver) TTL/RS422
Shaft insulation	2.8 kV
Transmission length	≤ 350 m at 100 kHz (HTL-P) ≤ 550 m at 100 kHz (TTL)
Interference immunity	EN 61000-6-2
Emitted interference	EN 61000-6-3
Approvals	CE, UL/ CSA approval / E256710

Features

- Robust, compact housing
- Two bearings with large distance, one at each end
- High shaft load up to 450 N
- Shock resistant up to 250 g
- Shaft insulation up to 2.8 kV
- Highest operating speed 10000 rpm
- Terminal box, turn by 180°

Optional

- Hybrid bearing for extended lifetime
- Function control (EMS)

Technical data - mechanical design

Size (flange)	$\varnothing 99$ mm
Shaft type	$\varnothing 12...16$ mm (blind hollow shaft) $\varnothing 17$ mm (cone shaft 1:10)
Admitted shaft load	≤ 350 N axial ≤ 450 N radial
Motor shaft tolerance	0.2 mm radial
Protection DIN EN 60529	IP 66
Operating speed	≤ 10000 rpm (mechanical)
Operating torque	≤ 6 Ncm
Rotor moment of inertia	160 gcm ²
Materials	Housing: aluminium, coated Shaft: stainless steel
Operating temperature	-40...+100 °C -40...+90 °C (fixed cable) -25...+100 °C (>3072 pulses per revolution)
Resistance	IEC 60068-2-6 Vibration 15 g, 10-2000 Hz IEC 60068-2-27 Shock 250 g, 6 ms
Corrosion protection	IEC 60068-2-52 Salt mist Complies to ISO 12944-5:1998 Protective paint systems (C4)
Explosion protection	II 3 G Ex nA IIC T4 Gc (gas) II 3 D Ex tc IIIC T135°C Dc (dust)
Connection	Terminal box Flange connector M23, 12-pin Cable 1 m
Weight approx.	1.3 kg

Incremental encoders

Insulated blind hollow shaft $\varnothing 12...16$ mm, cone shaft $\varnothing 17$ mm

500...5000 pulses per revolution

HOG 86

Part number

Incremental encoder

HOG 86

					DN				
--	--	--	--	--	----	--	--	--	--

Voltage supply / signals
 I 9...30 VDC / output circuit HTL with inverted signals
 T 5 VDC / output circuit TTL with inverted signals
 R 9...30 VDC / output circuit TTL with inverted signals

Pulse number - see table

Output signals
 DN K1, K2, K0 + inverted

Shaft diameter
 2 Blind hollow shaft $\varnothing 12$ mm, fit H7
 6 Blind hollow shaft $\varnothing 16$ mm, fit H7
 7 Cone shaft $\varnothing 17$ mm (1:10)
 8 Blind hollow shaft $\varnothing 16$ mm, fit G7
 9 Blind hollow shaft $\varnothing 12$ mm, fit F6

Insulation
 H Hybrid bearing
 P PA insulated

Connection
 T 1 terminal box, radial
 F 1 flange connector M23, radial
 K Cable 1 m, radial

EMS - Enhanced Monitoring System

Without EMS

.2 With EMS

Pulse number

500	1000	1250	2500	4096
512	1024	2048	3072	5000

Other pulse numbers on request.

Accessories

Connectors and cables

HEK 8	Sensor cable for encoders
11068577	Mating connector M23, solder version, 12-pin, CCW

Mounting accessories

11077087	Mounting and dismounting set
11071906	Mounting kit earthing strap
DMS 6	Torque arm size M6
11071850	Support plate mounting kit R63 for torque arm size M6
11082676	Support plate mounting kit R69 for torque arm size M6
11072076	Screw mounting kit for torque arm size M6

Mounting accessories

11071904	Mounting kit for torque arm size M6
----------	-------------------------------------

Diagnostic accessories

HENQ 1100	Analyzer for encoders
-----------	-----------------------

Incremental encoders

Insulated blind hollow shaft $\varnothing 12...16$ mm, cone shaft $\varnothing 17$ mm

500...5000 pulses per revolution

HOG 86

Output signals

At positive rotating direction

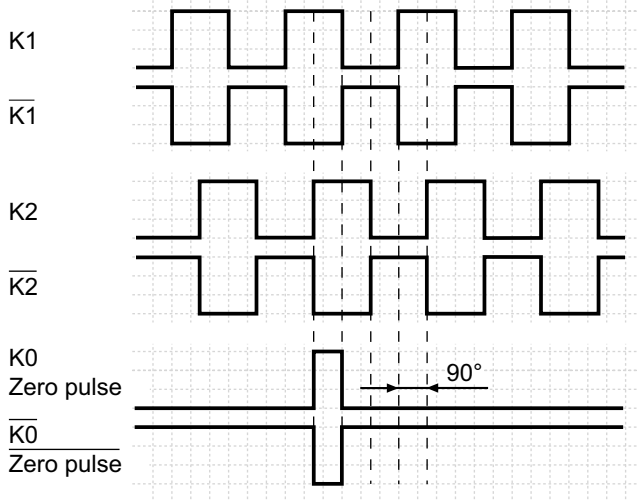

Option EMS: LED status / Error output

Flash light red*	Error of signal sequence, zero pulse or pulses (Error output = HIGH-LOW alternation)
Red	Overload output driver (Error output = LOW)
Flash light green	Encoder o.k., rotating (Error output = HIGH)
Green	Encoder o.k., stopped (Error output = HIGH)
No light	No output voltage connection or wrong connection (Error output = LOW)

* Only at rotating encoder

Terminal significance

+UB	Voltage supply (for the encoder)
\perp ; \downarrow ; GND; 0 V	Ground (for the signals)
\perp ; \nearrow	Earth ground (chassis)
K1; A; A+	Output signal channel 1
$\overline{K1}$; \overline{A} ; A-	Output signal channel 1 inverted
K2; B; B+	Output signal channel 2 (offset by 90° to channel 1)
$\overline{K2}$; \overline{B} ; B-	Output signal channel 2 (offset by 90° to channel 1) inverted
K0; C; R; R+	Zero pulse (reference signal)
$\overline{K0}$; \overline{C} ; \overline{R} ; R-	Zero pulse (reference signal) inverted
Err; Err-	Error output

Terminal assignment

HOG 86 T - View A

Connecting terminal terminal box

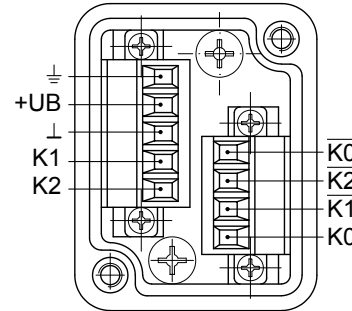

HOG 86.2 T - View A

Connecting terminal terminal box

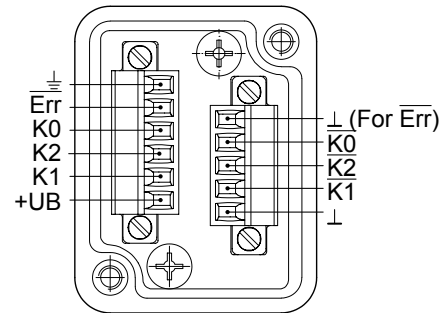

HOG 86(.2) F - View B

Flange connector M23, 12-pin, male, CW

HOG 86(.2) K

Pin	Assignment	Wire colour
1	K2	Yellow
2	Do not use	-
3	K0	Grey
4	$\overline{K0}$	Pink
5	K1	White
6	$\overline{K1}$	Brown
7	Do not use (With EMS: \overline{Err})	Violet
8	K2	Green
9	Do not use (With EMS: \perp)	Black
10	\perp	Blue
11	Do not use	-
12	+UB	Red

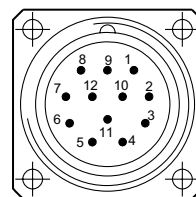

Incremental encoders

Insulated blind hollow shaft $\varnothing 12...16$ mm, cone shaft $\varnothing 17$ mm

500...5000 pulses per revolution

HOG 86

Dimensions

HOG 86 T - Version with radial terminal box

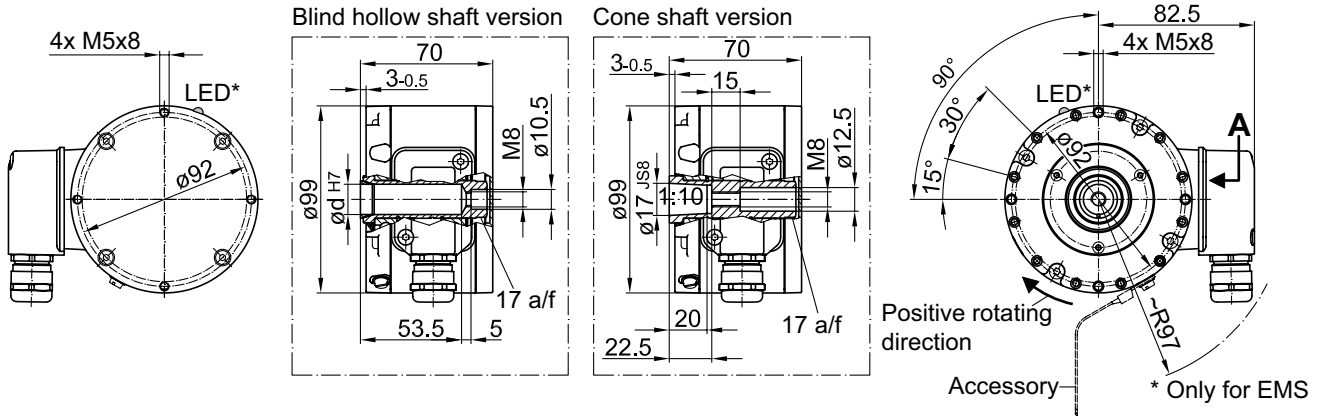

HOG 86 F - Version with radial connector M23, HOG 86 K - Version with radial connecting cable

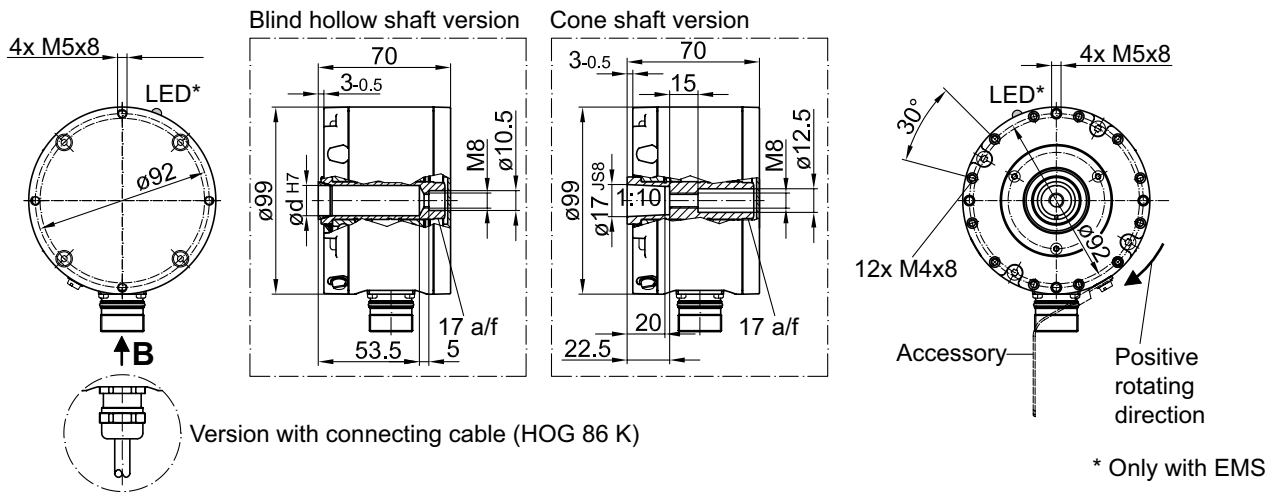

HOG 86 - Mounting possibilities

